

LUBRICATE ALL SEALS WITH CLEAN HYDRAULIC OIL PRIOR TO ASSEMBLY. DO NOT USE SILICONE BASED LUBRICANTS.

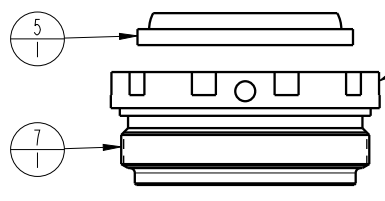

TIGHTEN TO 55 FT-LBS TORQUE  
USE VEKTEK TORQUE TOOL  
NEW STYLE TORQUE TOOL AT200151, 10 POINTED TOOL (CIRCA 2018)  
OLD STYLE TORQUE TOOL AT200150, 2 POINTED SPANNER HOLE TOOL

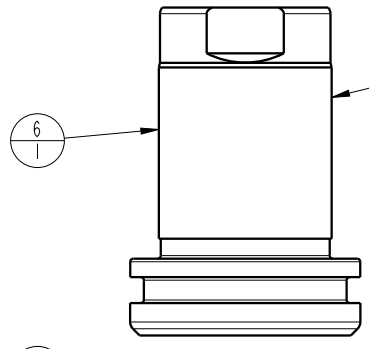

PISTON KIT INCLUDES PISTON AND RETAINING RING 23050013  
INSTALL WITH LIPS DOWN

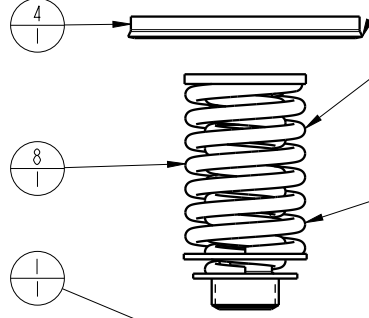

SPRING PAK REMOVAL - INSERT 1/8" INTERNAL HEX WRENCH THRU SAE 4 PORT INTO SPRING PAK RETAINER AND ROTATE CLOCKWISE AS VIEWED FROM BOTTOM. (REINSTALL - REVERSE ABOVE PROCEDURE)

SPRING KIT 61200115 INCLUDES SPRING PAC 92060003 AND BOTH RETAINING RINGS 23002003 & 23050013

RETAINING RING, 23002003 (NARROW GROOVE) OLD STYLE

RETAINING RING, 23050013 (WIDE GROOVE) CURRENT STYLE, CIRCA 08/01/2003

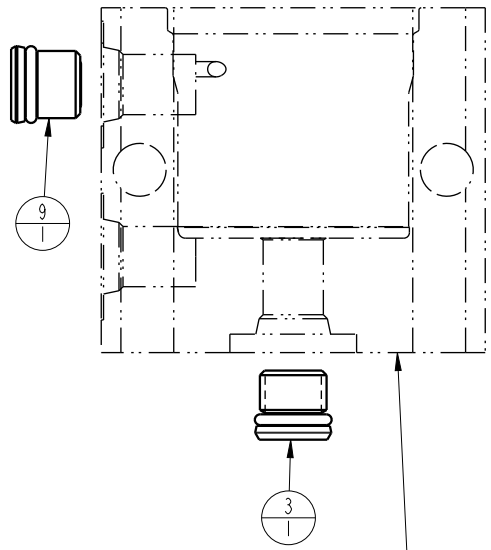

N/A	N/A	61200115	KIT, SPRING	N/A	N/A	NOTED
N/A	N/A	6V200115	KIT, SEAL, FKM	N/A	NOTED	N/A
N/A	N/A	60200115	KIT, SEAL, STANDARD	NOTED	N/A	N/A
9	I	92090001	ASSY, BREATHER, SAE #4			
8	I	92060003	SPRING PAK, CYL, 8800, 0.5 STRK			X
7	I	82031501	GLAND, CYL, 8800 & 39.9 KN			
6	I	62201504	Kit, Piston, Ring & Tag, 8800, 0.5 STRK			
5	I	39050020	WIPER, SNAP-IN, (1-1/8)	X	X	
4	I	39011028	SEAL, BEVEL, 1-5/16 X 3/32 X 1-1/2	X	39012015	
3	I	30601144	PLUG, SOCH, SAE 4			
2	I	23050013	SNAP RING, INTERNAL			X
1	I	23002003	SNAP RING, INTERNAL			X
No.	QTY	PART No.	DESCRIPTION	Standard Seal Kit	FKM Seal Kit	Spring Kit

BODY, NOT A REPLACEMENT PART

TIGHTEN SAE 4 SOCH PLUG AND SAE 4 BREATHER ASSEMBLY TO 7 FT-LBS TORQUE

### PARTS LIST



VEKTEK, INC.  
1334 E. SIXTH AVE. P.O. BOX 625  
EMPORIA, KS. 66801 U.S.A.

ASSEMBLIES AFFECTED	PARTS LIST, ASSY, CYL, BB, 8800, 0.5 STRK, SA
20111500	
20111500F	
SIZE A	PL2061
	REV J

J	5499	RELEASE	NPETERS	9/23/24
REV	IN ACCORDANCE WITH ECN	EFFECTIVE DATE	REVISED BY	DATE
DRW BY: JACOB	<b>DRAWING STATUS: Released</b>			
DATE: 08/06/90	PRODUCTION APPROVED FOR RELEASED STATUS ONLY			